



Vibration Testing and Troubleshooting of Coke Drums

Mahmod Samman, Ph.D., P.E.

Senior Associate

Stress Engineering Services, Inc.

mms@stress.com

Coking.com Coke Drum Workshop

Rio de Janeiro, Brazil

August 2009

OVERVIEW

- Vibrations Basics
- Drum Dynamics
- What is Affected
- Potential Consequences
- Case study

VIBRATIONS BASICS

- Response of a flexible structure to excitation (fluid flow, pressure pulsations, sloshing, etc..)
- Components
 - Mass (inertia)
 - Spring stiffness (Force–Displacement)
 - Dashpot viscous damping (Force–Velocity)
- Basic characteristics:
 - Natural frequency (or frequencies)
 - Mode shapes
- Input – output
 - Force
 - Displacement

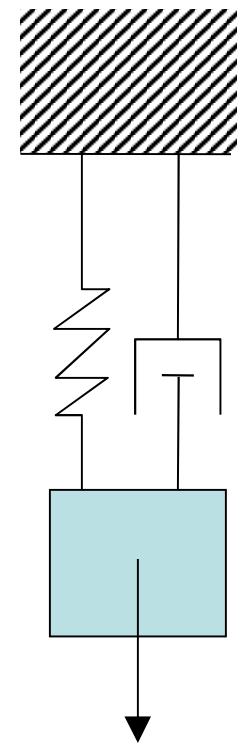

DRUM DYNAMICS

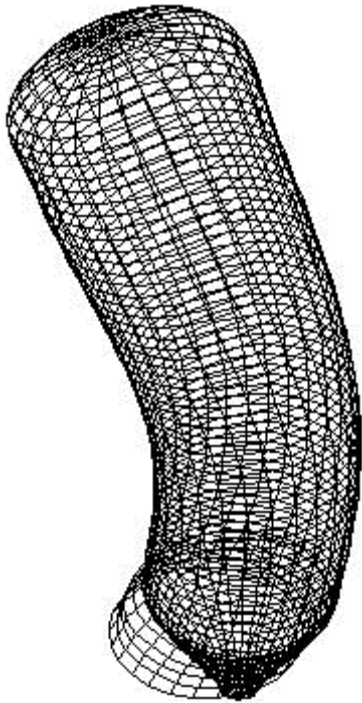

all 3d model of 28.5' drum
5-tiedcoke.odb ABAQUS/STANDARD
rvalue solution
10342. Freq = 16.185

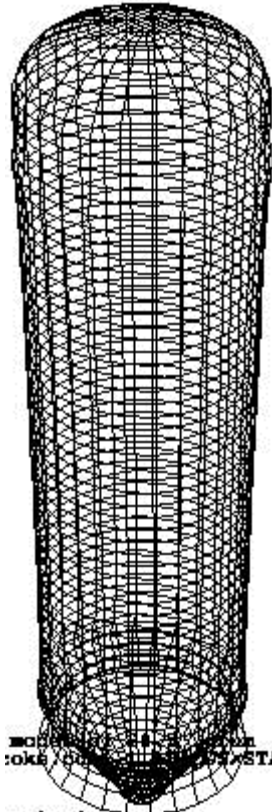

all 3d model of 28.5' drum
5-tiedcoke.odb ABAQUS/STANDARD
rvalue solution
10342. Freq = 18.377



all 3d model of 28.5' drum
5-tiedcoke.odb ABAQUS/STANDARD
rvalue solution
34446. Freq = 29.547

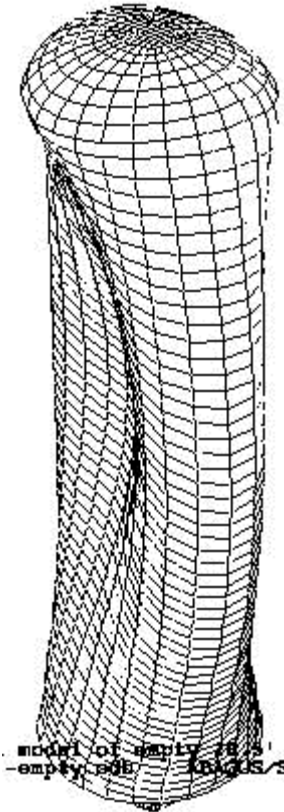

all 3d model of empty 28.5' drum
5-empty.odb ABAQUS/STANDARD

WHAT IS AFFECTED

- Pipes and pipe supports
- Base-plate bolts and grout
- Non-structural (stairs, lights, guardrails,..)
- Machinery (elevator, pumps, ..)
- Superstructure (concrete and steel)
- Foundation system (substructure and soil)

- Humans!

POTENTIAL CONSEQUENCES

- Operator discomfort or fatigue
- Poor performance
- Acceleration of corrosion damage
- Interruption of operations during repairs
- Fatigue cracks (leaks/ fires)
- Bodily injuries

WHAT TO DO?

- Measure
 - Vibrations
 - Strain
 - Process variables
- Analyze
 - Stress / fatigue
 - Human tolerance
- Mitigate
 - Process
 - Structure

CASE STUDY - 1

- Two-drum unit
- “Significant” vibrations in structure
- Conflicting views on
 - When they vibrate the most
 - Which one vibrates more
- Failures
 - Piping supports
 - Anchor bolts
 - Base plate grout
- Is the unit safe?
- Can the process be optimized to minimize vibrations?



DRUM DESIGN AND OPERATION

1996 API Coke Drum Survey, 2003

- 16 feet in diameter - relatively small for the mid 80's
- 76 feet in height - average to tall
- Slender drums
- Very common 1 ¼ Cr -1/2Mo material
- 17 hour fill cycle - average to relatively slow operation

OBJECTIVES

- Monitor vibrations in the drums, piping, and structure.
- Obtain synchronized temperature and strain measurements.
- Determine the timing and characteristics of maximum vibrations.
- Determine severity of dynamic stresses and potential for fatigue damage in the structure.
- Conduct sensitivity analysis of vibrations versus process variables.

PROCEDURE

- Installed 33 sensors and two data acquisition systems on the drums, piping, and structure.
- Monitored the unit for a period of 20 days (14 cycles)
- Processed and analyzed the data in time and frequency domain.
- Analyzed the correlation between key process variables with vibration, strain, and temperature measurements.

INSTRUMENTATION

Vibration data acquisition system

- 16 channel unit

- 16 seismic accelerometers @ 102 samples per second

- 2 strain gages (low-speed DC channels)

Temperature data acquisition system

- StrainDAQ unit

- 16 thermocouples

- 1 sample per two seconds

Data collection was continuous without interruption during the entire monitoring period.

Sensor Layout

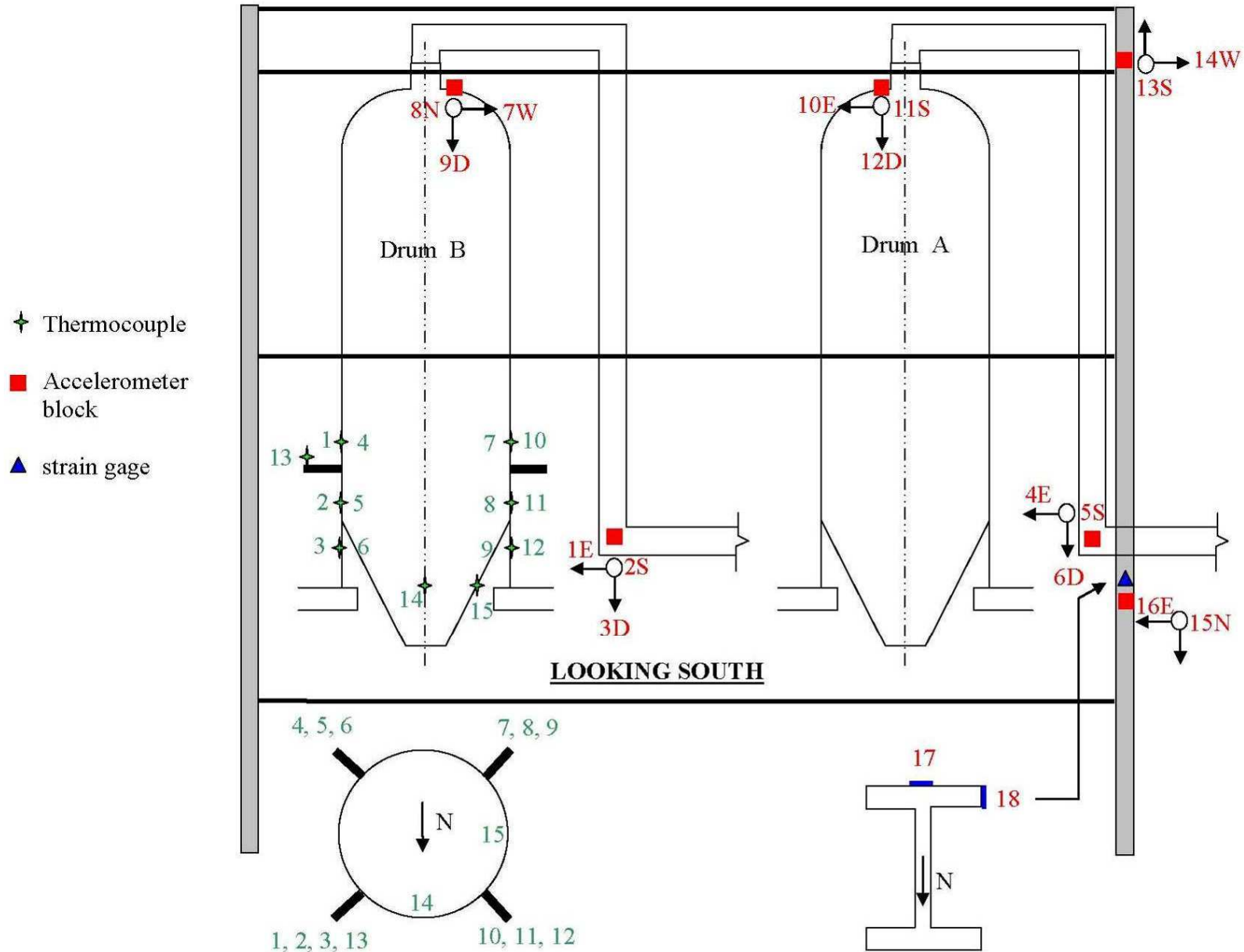

Example Quench Transient

TEMPERATURE

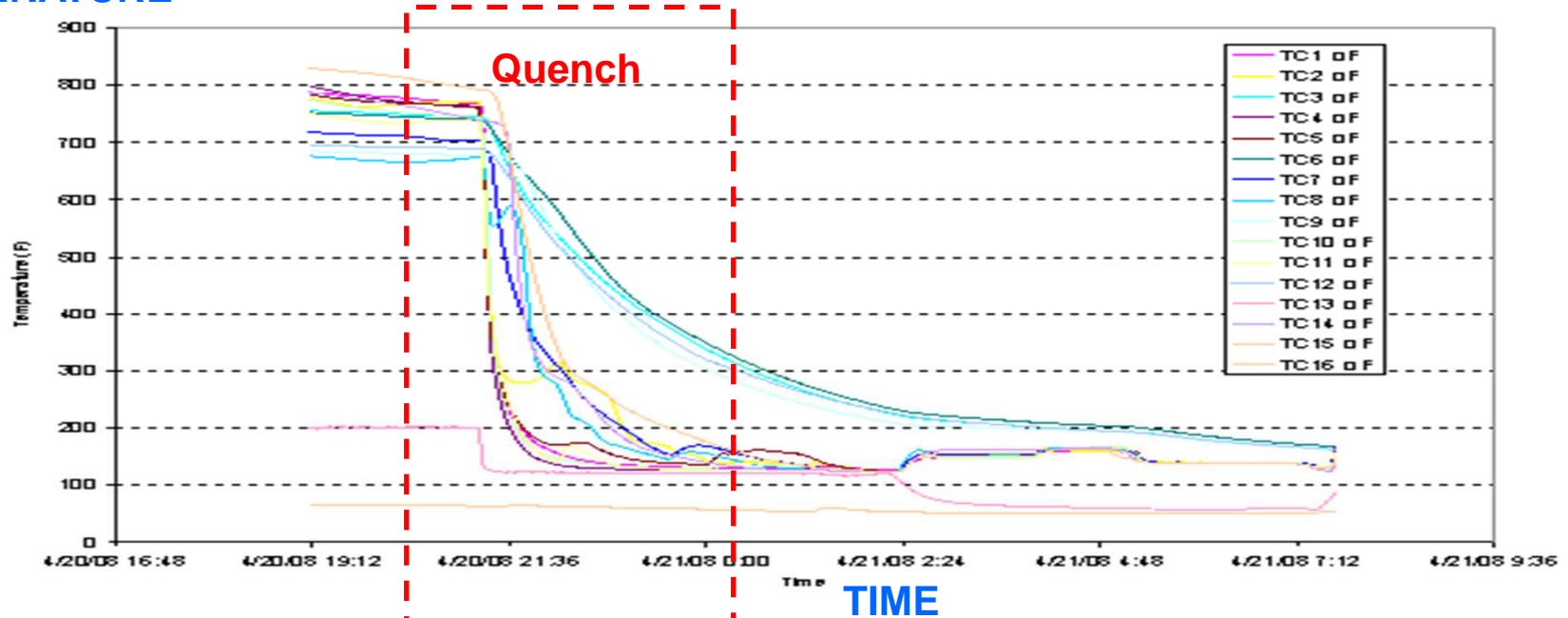

TIME

ACCELERATION

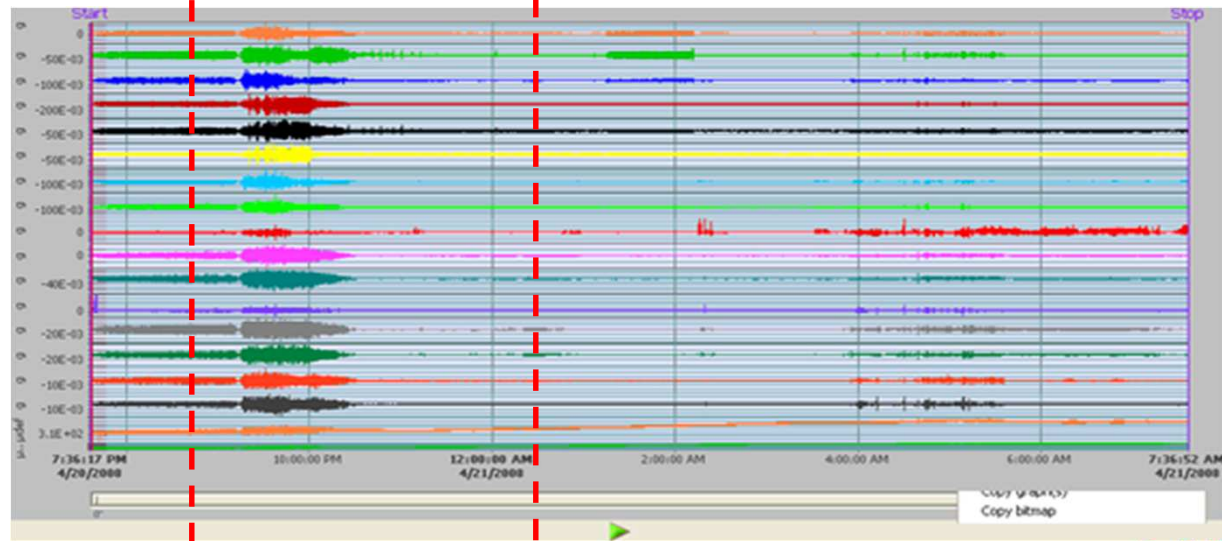

Integrated Displacement Data

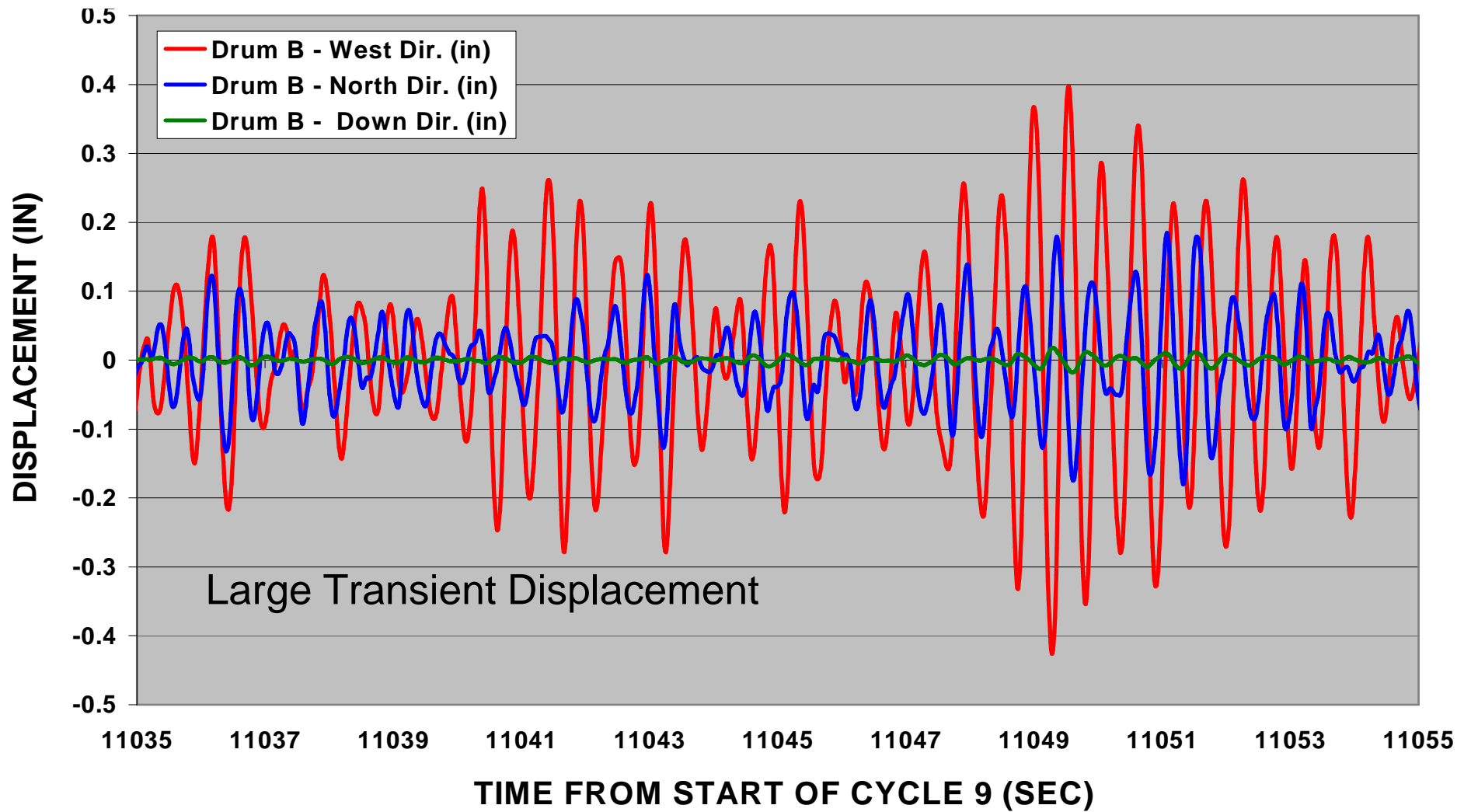

Vibration Versus Flow Rate

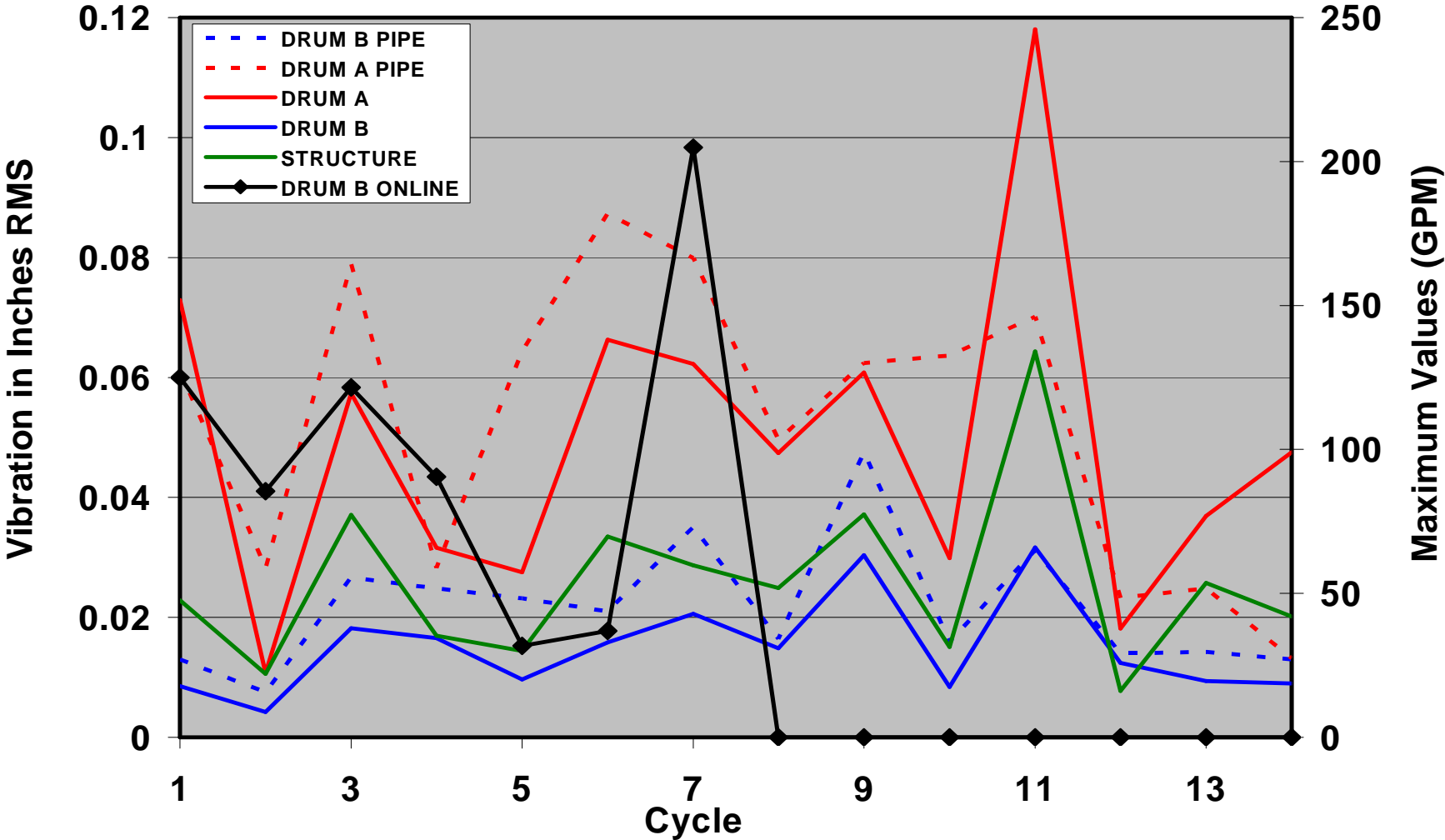

Strain Gauge Data

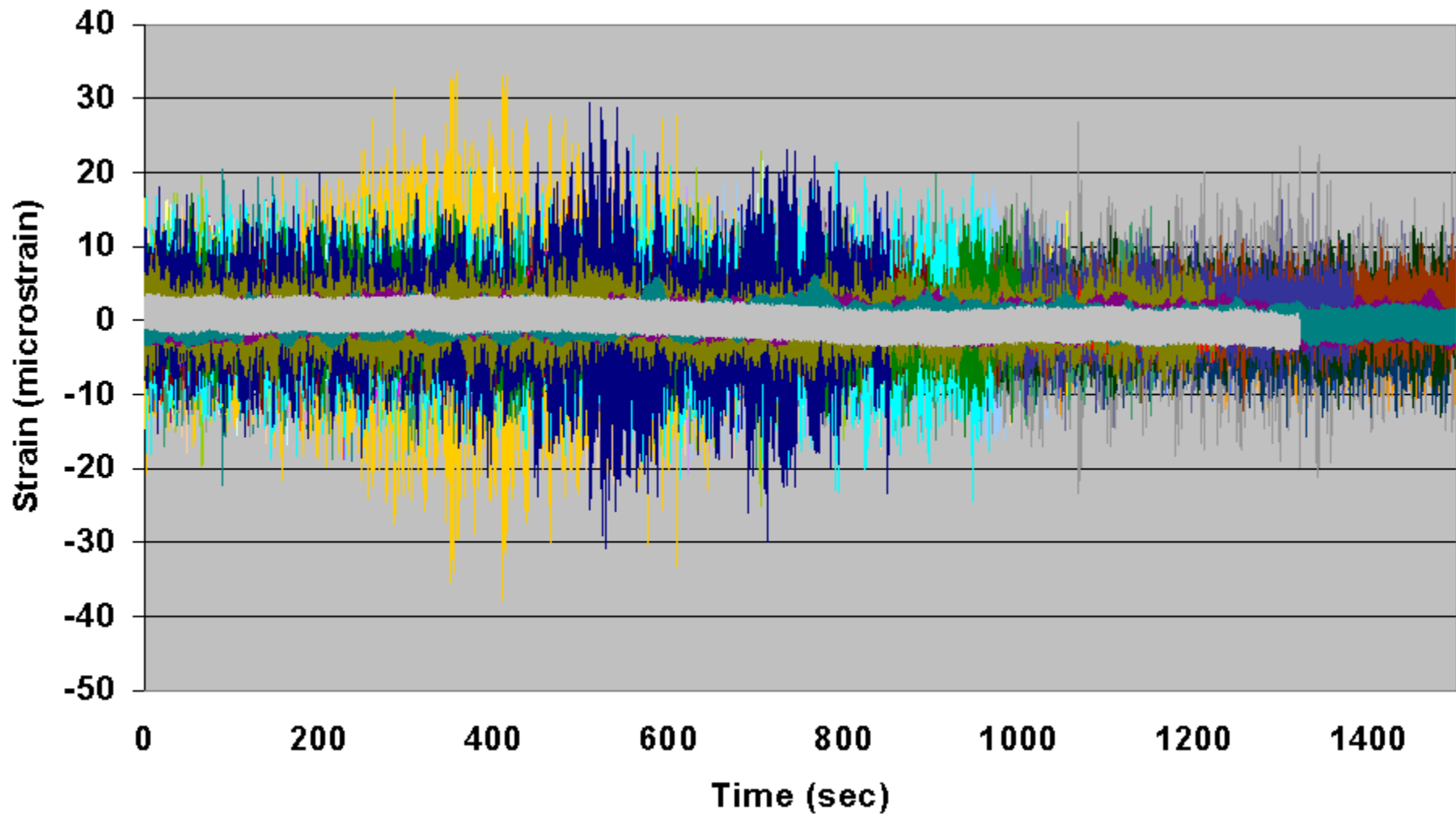

CASE-1 SUMMARY

- Drum vibration magnitude was maximum during the quench part of the cycle in the East-West direction.
- The two drums vibrated in a comparable manner both from magnitude and frequency standpoints.
- The maximum recorded peak displacements were 0.58, 0.35, and 0.23 inches for the drums, the piping, and the structure, respectively.
- Measured dynamic strains in the structure were below the fatigue-inducing levels
- The correlation between vibration levels and recorded process parameters was established

CASE STUDY -2

- Four-drum unit.
- Blow-down line.
- Cracks and leaks.
- Angled-tee joint.
- Thermal cycles.
- 3D loads.
- Vibrations.
- Why?
- How to fix it?



ACTION PLAN

1. Instrumentation
 - Strain gages
 - Thermocouples
2. Extraction of loading conditions
3. Finite element analysis
4. Fatigue Assessment

INSTRUMENTATION

Intrinsically Safe Instrumentation System



FIELD MONITORING

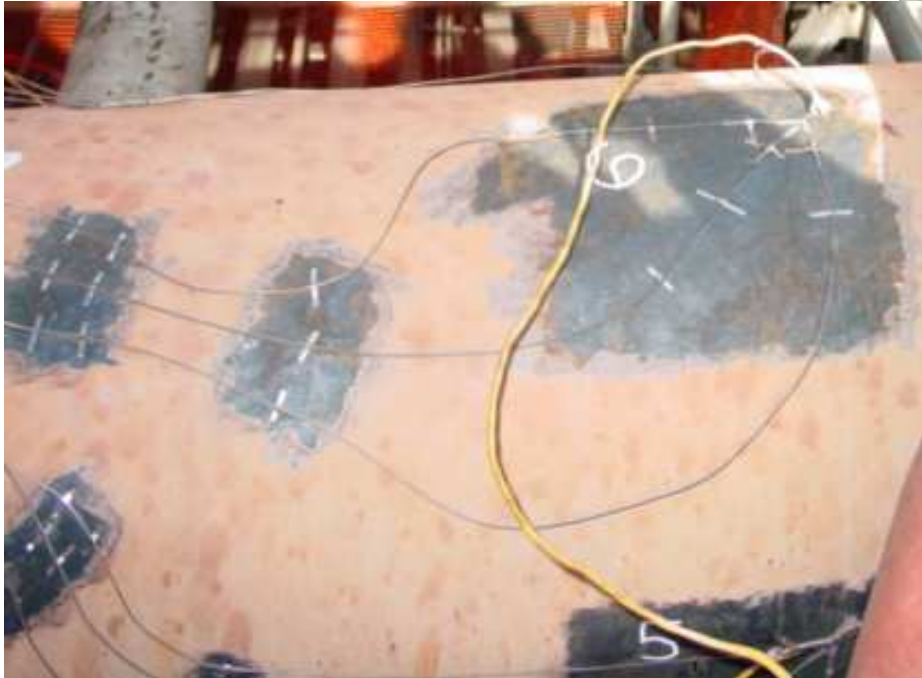

TEMPERATURE MEASUREMENTS

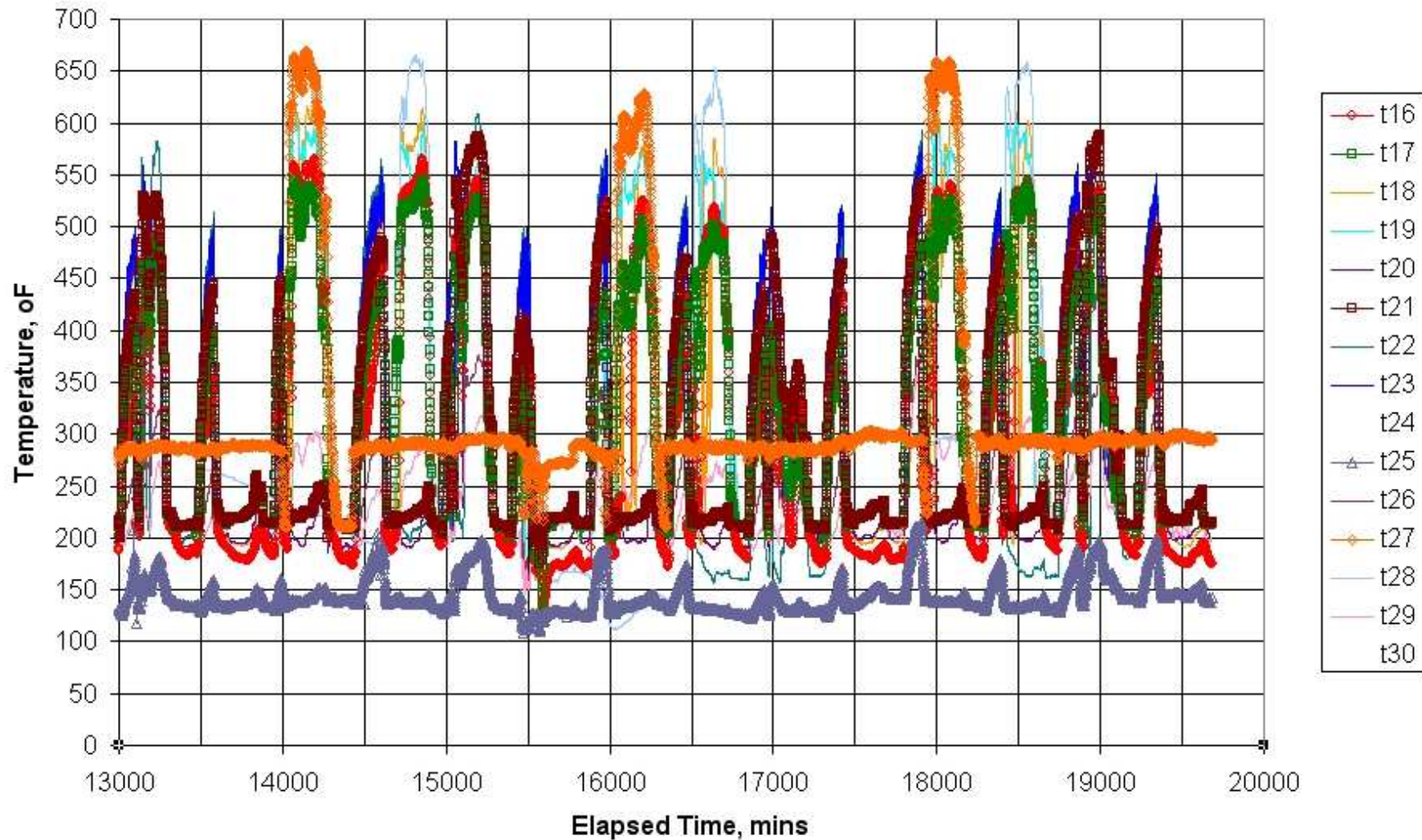

THERMAL GRADIENTS

Every fourth cycle

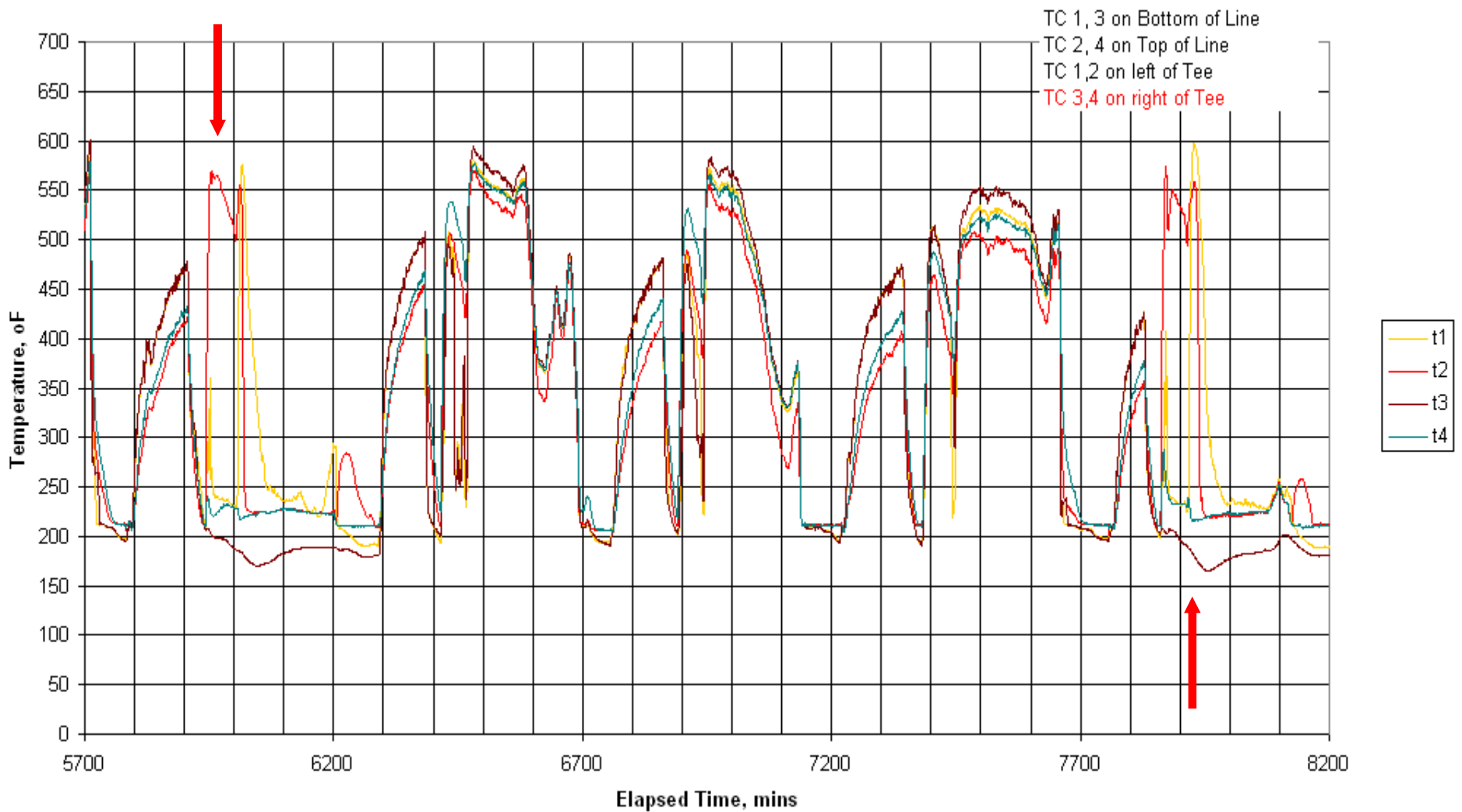

CLOSEUP

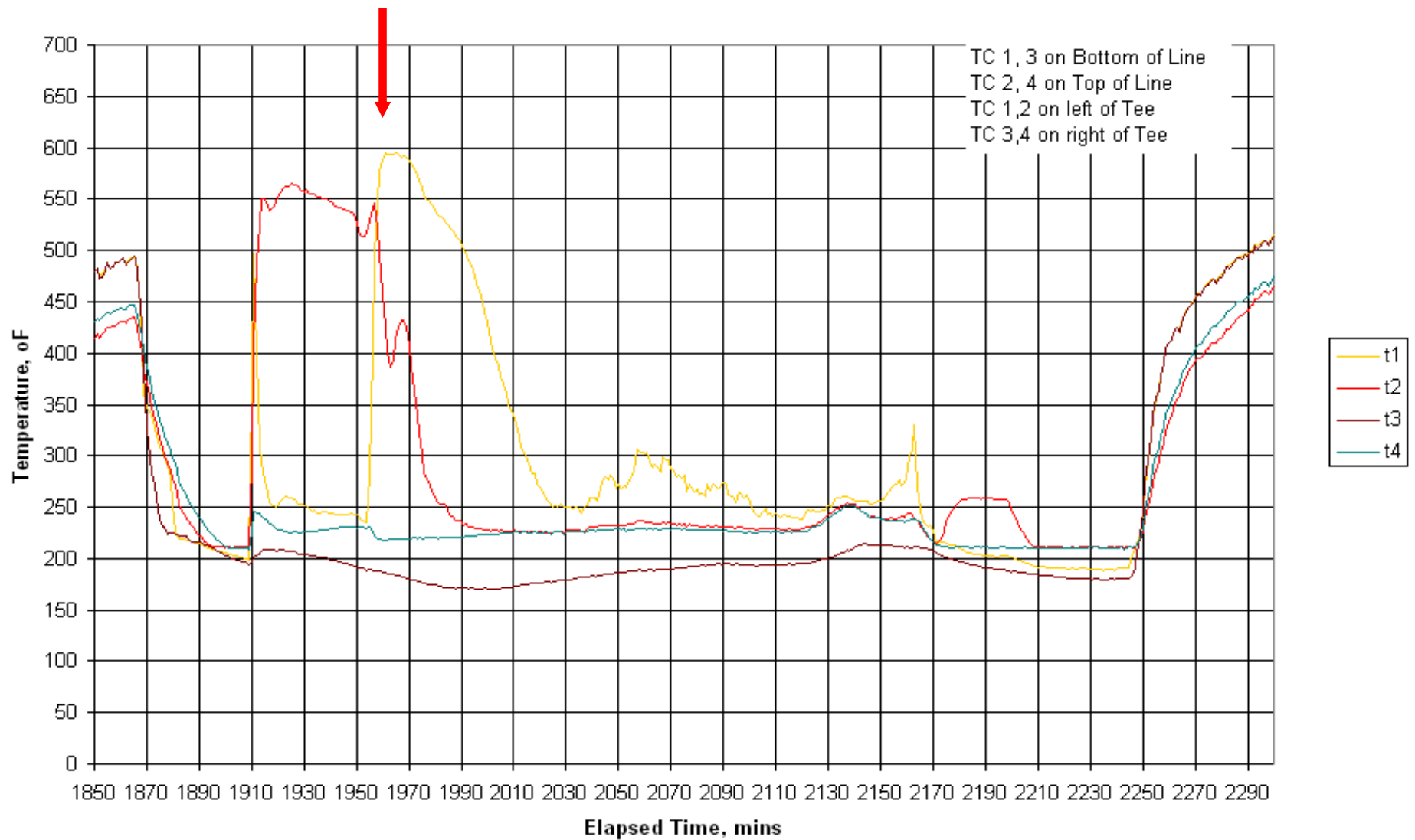

PAD THERMAL GRADIENTS

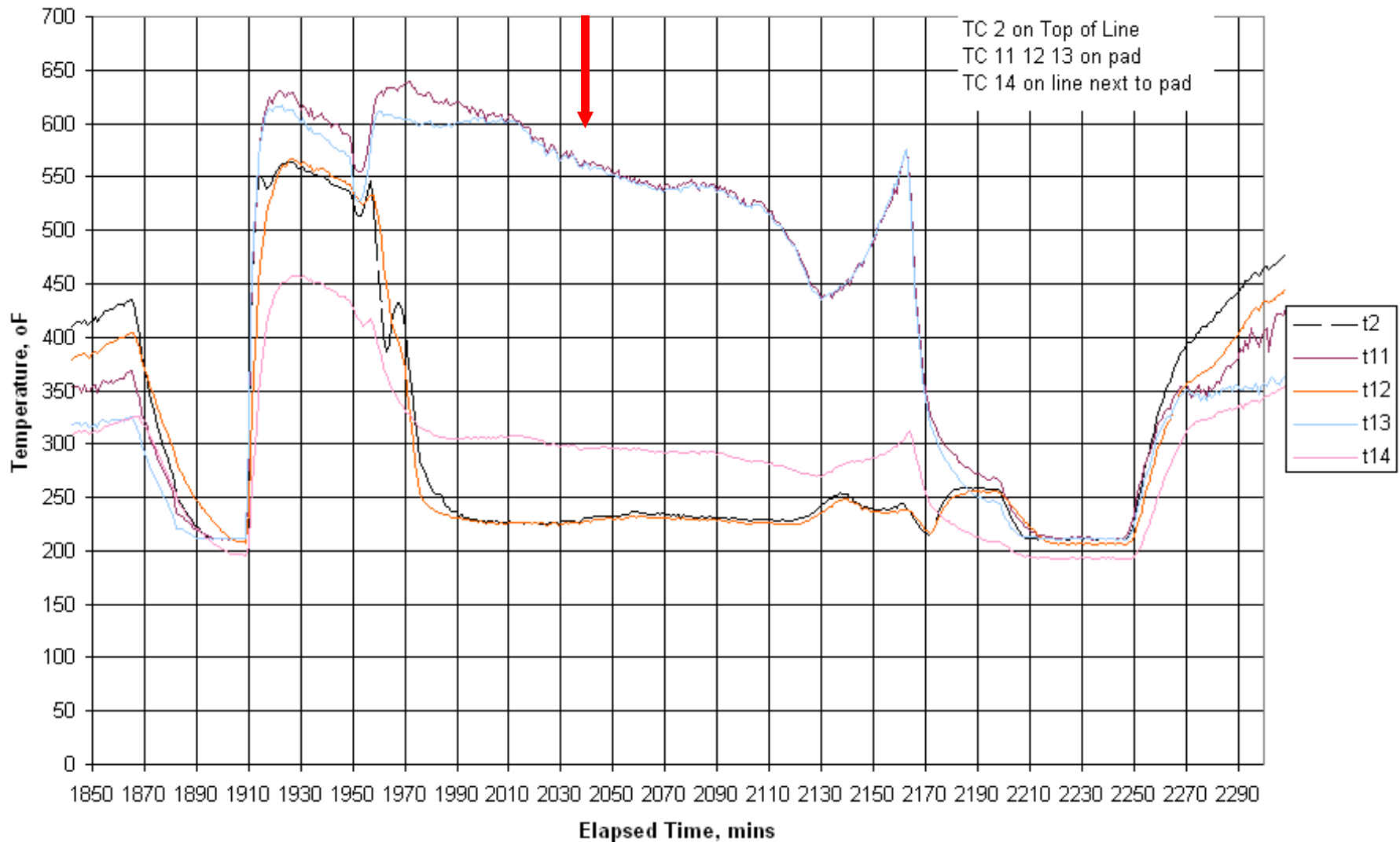

Extracted load cases

Five thermal profiles during the coking cycle

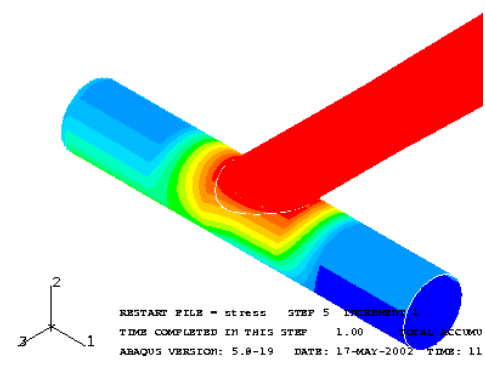
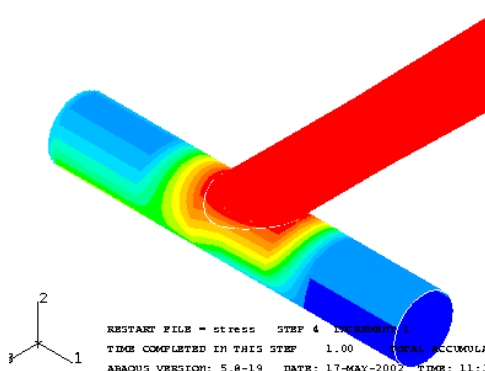
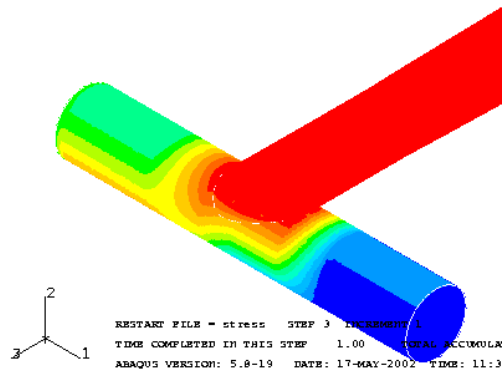
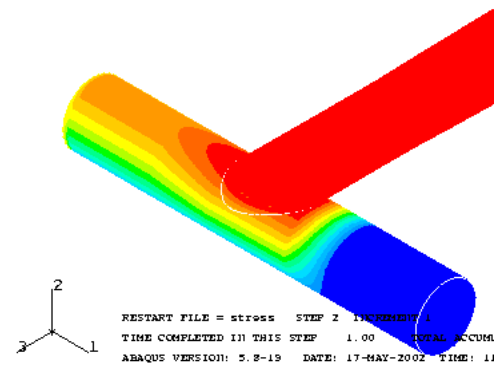
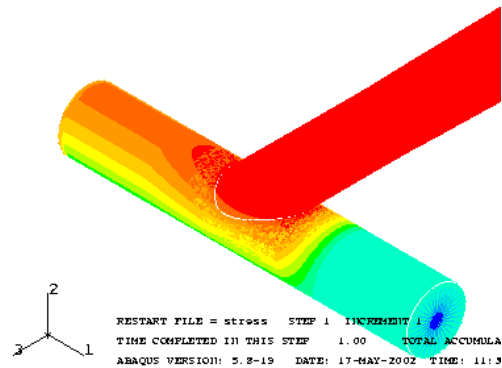

Thermal Load Case

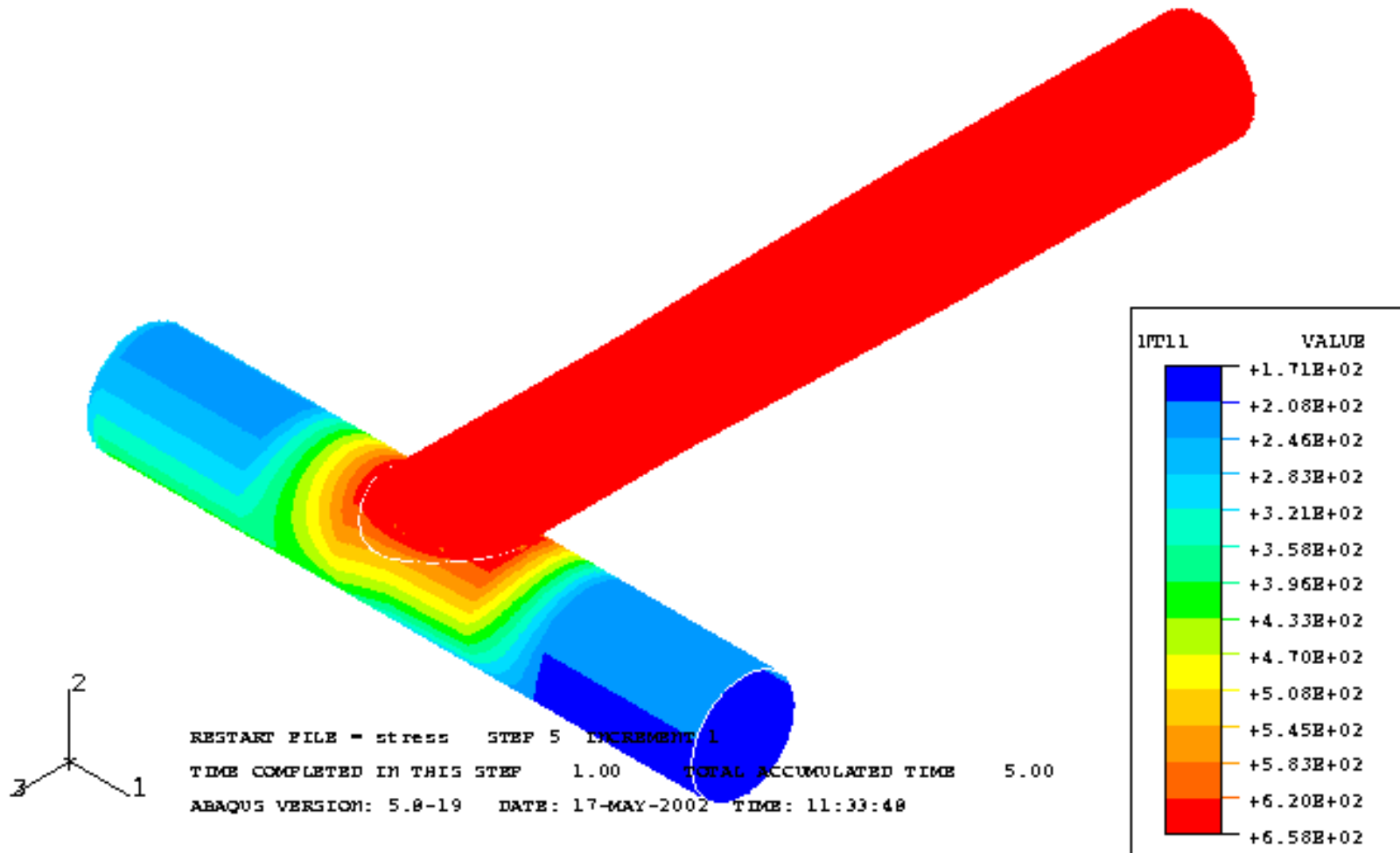

Von Mises Stress in the pipe

outside

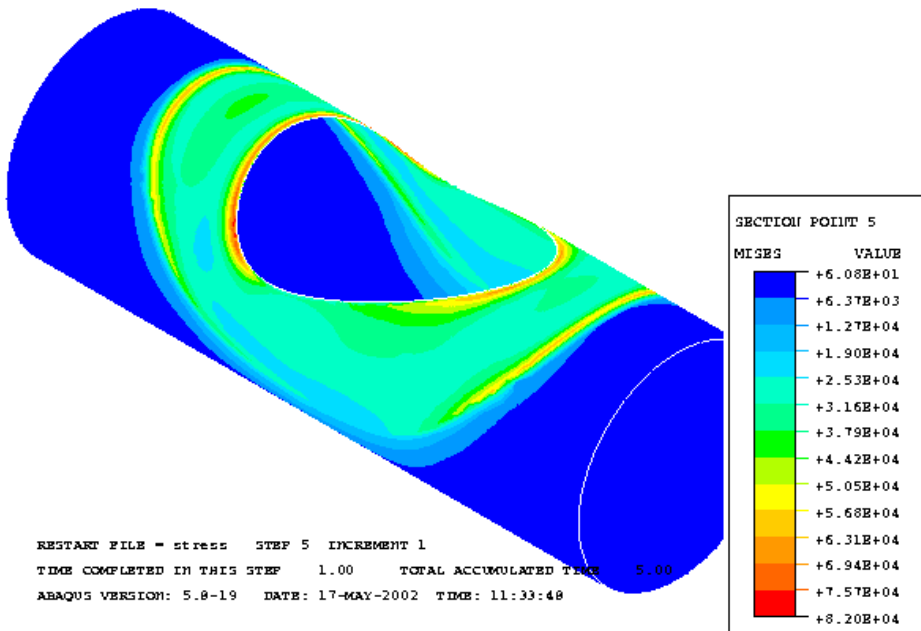

inside

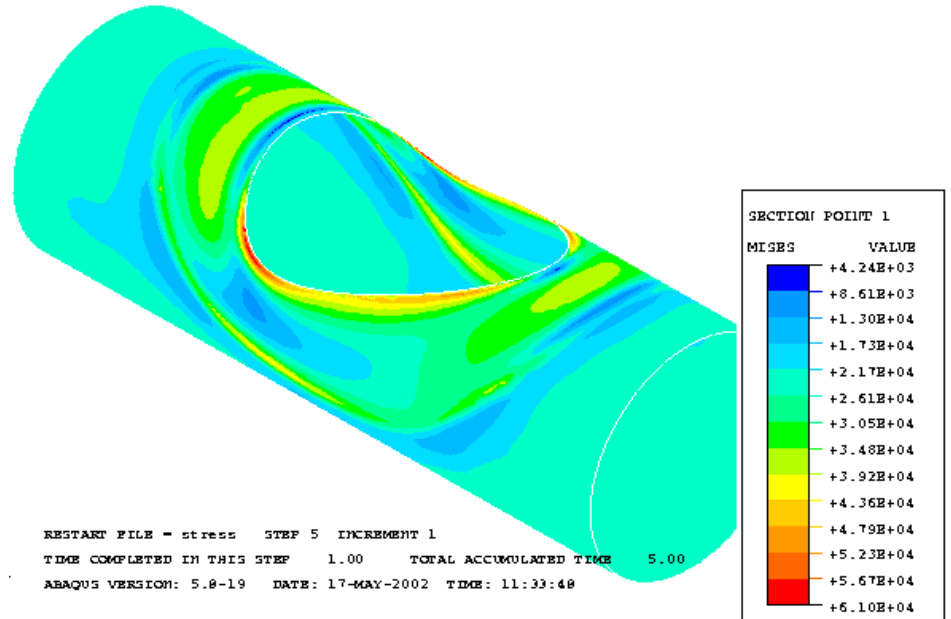

Von Mises Stress inside the pad

outside

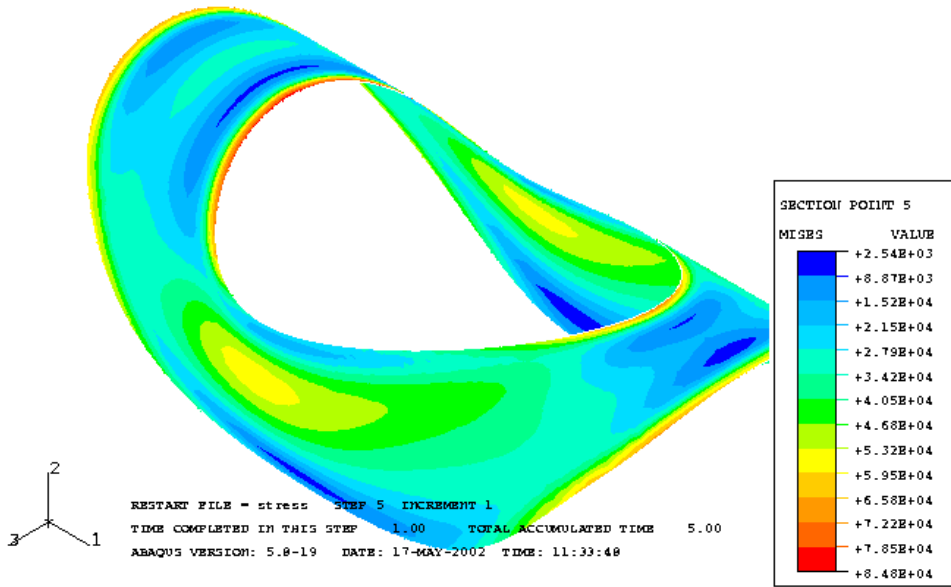

inside

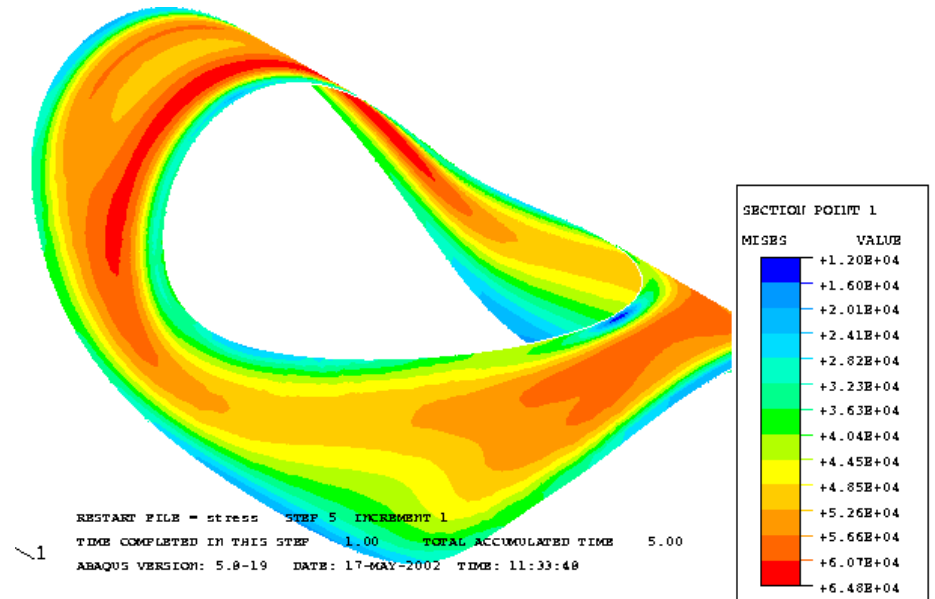

Fatigue Assessment

- Maximum thermal stress range is 92 ksi.
- Alternate stress is 49.8 ksi.
- Correction for E at 400⁰F
- Fatigue life is 4,441 cycles.

CASE-2 SUMMARY

- Vibrations and pressure are not the main problem.
- The failure is caused by severe thermal transients that generate 92 ksi stress range in the pipe at the location of cracks.
- Recommendations to minimize stresses and increase fatigue life:
 - Redesigned integral fitting.
 - Fatigue-resistant welds.

Questions?

Mahmod Samman, Ph.D., P.E.
Stress Engineering Services, Inc.
281-955-2900
mms@stress.com